



**HIGH-PERFORMANCE  
RF MODULE**  
RXM-900-HP3-xxx



**WIRELESS MADE SIMPLE®**

## HP3 SERIES RECEIVER MODULE DATA GUIDE

### DESCRIPTION

The HP3 RF receiver module offers complete compatibility and numerous enhancements over previous generations. The HP3 is designed for the cost-effective, high-performance wireless transfer of analog or digital information in the popular 902-928MHz band. All HP3 Series modules feature eight parallel selectable channels, but versions are also available which add serial selection of 100 channels. To ensure reliable performance, the receiver employs FM / FSK demodulation and an advanced dual-conversion microprocessor-controlled synthesized architecture. The receiver is pin- and footprint-compatible with all previous generations, but its overall physical size has been reduced. Both SMD and pinned packages are available. When paired with an HP3 transmitter, a reliable link is created for transferring analog and digital information up to 1,000 feet. (under optimal conditions). As with all Linx modules, the HP3 requires no tuning or additional RF components (except an antenna), making integration straightforward even for engineers without prior RF experience.

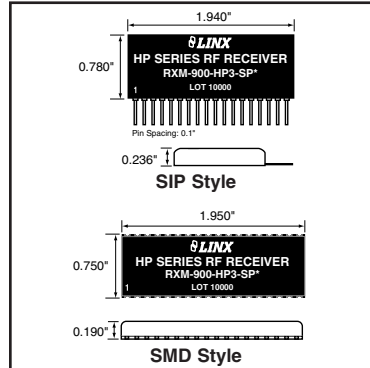

Figure 1: Package Dimensions

### FEATURES

- 8 parallel / 100 serial (PS Versions) user-selectable channels
- FM / FSK demodulation for outstanding performance and noise immunity
- Exceptional sensitivity (-100dBm typical)
- Wide-range analog capability including audio (50Hz to 28kHz)
- RSSI and Power-down lines
- Precision frequency synthesized architecture
- No external RF components required
- Compatible with previous HP Series modules
- High data rate (up to 56kbps)
- Wide supply range (2.8 to 13.0VDC)
- Direct serial interface
- Pinned and SMD packages
- Wide temperature range (-30°C to +85°C)

### APPLICATIONS INCLUDE

- Wireless Networks / Data Transfer
- Wireless Analog / Audio
- Home / Industrial Automation
- Remote Access / Control
- Remote Monitoring / Telemetry
- Long-Range RFID
- MIDI Links
- Voice / Music / Intercom Links

### ORDERING INFORMATION

PART #	DESCRIPTION
RXM-900-HP3-PPO	HP3 Receiver (SIP 8 CH only)
RXM-900-HP3-PPS	HP3 Receiver (SIP 8p / 100s CH)
RXM-900-HP3-SPO	HP3 Receiver (SMD 8 CH only)
RXM-900-HP3-SPS	HP3 Receiver (SMD 8p / 100s CH)
MDEV-900-HP3-PPS-USB	HP3 Development Kit (Pinned Pkg.)
MDEV-900-HP3-PPS-RS232	HP3 Development Kit (Pinned Pkg.)
MDEV-900-HP3-SPS-USB	HP3 Development Kit (SMD Pkg.)
MDEV-900-HP3-SPS-RS232	HP3 Development Kit (SMD Pkg.)

Receivers are supplied in tubes of 10 pcs.

# ELECTRICAL SPECIFICATIONS

Parameter	Designation	Min.	Typical	Max.	Units	Notes
<b>POWER SUPPLY</b>						
Operating Voltage	V <sub>CC</sub>	2.8	3.0	13.0	VDC	–
Supply Current	I <sub>CC</sub>	16.0	19.0	21.0	mA	1
Power-Down Current	I <sub>PDN</sub>	–	5.6	10.0	µA	2
<b>RECEIVE SECTION</b>						
Receive Frequency Range	F <sub>C</sub>	902.62	–	927.62	MHz	3
Center Frequency Accuracy		-50		+50	kHz	
Channel Spacing	–	–	250	–	kHz	3
First IF Frequency		–	34.7	–	MHz	4
Second IF Frequency		–	10.7	–	MHz	4
Noise Bandwidth	N <sub>3DB</sub>	–	280	–	kHz	–
Data Rate	–	100	–	56,000	bps	–
Analog / Audio Bandwidth	–	50	–	28,000	Hz	4
Analog / Audio Output Level		0.8	1.1	2.0	VAC	5
<b>Data Output:</b>						
Logic Low	–	0.0	–	0.5	VDC	6
Logic High	–	V <sub>CC</sub> -0.3	–	V <sub>CC</sub>	VDC	6
Output Impedance		–	17	–	kohms	–
Data Output Source Current		–	230	–	µA	7
Receiver Sensitivity		-94	-100	-107	dBm	8,9
<b>RSSI:</b>						
Dynamic Range		60	70	80	dB	4
Gain		–	24	–	mV/dB	4
Voltage With No Carrier		–	–	1.6	V	4
<b>Spurious Emissions</b>						
<b>Interference Rejection:</b>						
F <sub>C</sub> ±1MHz		–	54	–	dB	4
F <sub>C</sub> ±5MHz		–	57	–	dB	4
<b>ANTENNA PORT</b>						
RF Input Impedance	R <sub>OUT</sub>	–	50	–	Ω	4
<b>TIMING</b>						
<b>Receiver Turn-On Time:</b>						
via V <sub>CC</sub>	T <sub>4</sub>	–	–	7.0	mSec	4
via PDN	T <sub>3</sub>	–	–	3.0	mSec	4
Channel Change Time	T <sub>2</sub>	–	–	1.5	mSec	4
Max. time between transitions	T <sub>1</sub>	–	–	20	mSec	4
<b>ENVIRONMENTAL</b>						
Operating Temperature Range	–	-30	–	+85	°C	4

Table 1: HP3 Series Receiver Specifications

## Notes

- Over the entire operating voltage range.
- With the PDN pin low.
- Serial mode.
- Characterized, but not tested.
- With 1kHz sine wave @ 115kHz transmitter deviation
- No load.
- With 1V output drop.
- For 10<sup>-5</sup> @ 9,600bps.
- At specified center frequency.

# ABSOLUTE MAXIMUM RATINGS

Supply Voltage V <sub>CC</sub>	-0.3	to	+18.0	VDC
Any Input or Output Pin	-0.3	to	V <sub>CC</sub>	VDC
Operating Temperature	-30	to	+85	°C
Storage Temperature	-45	to	+85	°C
Soldering Temperature	+260°C for 10 seconds			

**\*NOTE\*** Exceeding any of the limits of this section may lead to permanent damage to the device. Furthermore, extended operation at these maximum ratings may reduce the life of this device.

## PERFORMANCE DATA

These performance parameters are based on module operation at 25°C from a 3.0VDC supply unless otherwise noted. Figure 2 illustrates the connections necessary for testing and operation. It is recommended all ground pins be connected to the ground plane. The pins marked NC have no electrical connection.

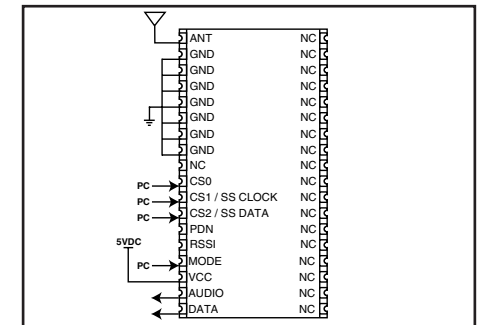

## PIN ASSIGNMENTS

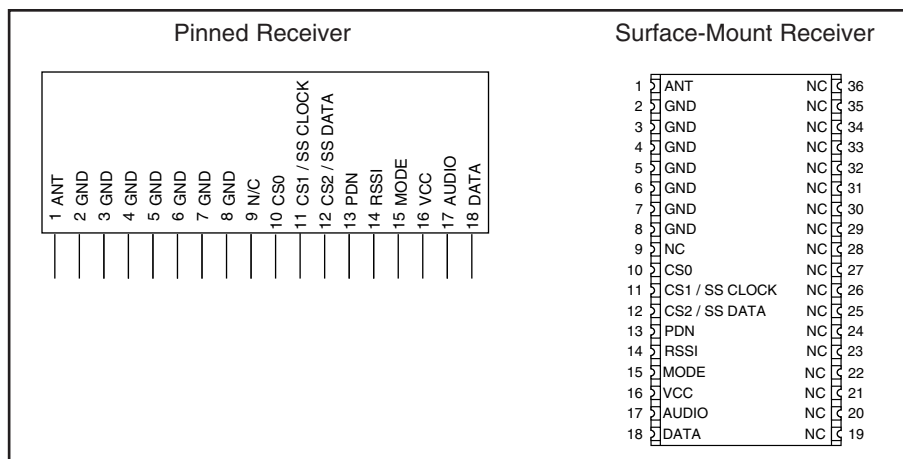

Figure 7: HP3 Series Receiver Pinout

Pin #	Name	Description
1	ANT	50-ohm RF Input
2-8	GND	Analog Ground
9	NC	No Connection
10	CS0	Channel Select 0
11	CS1 / SS CLOCK	Channel Select 1 / Serial Select Clock. Channel Select 1 when in parallel channel selection mode, clock input for serial channel selection mode.
12	CS2 / SS DATA	Channel Select 1 / Serial Select Data. Channel Select 2 when in parallel channel selection mode, data input for serial channel selection mode.
13	PDN	Power Down. Pulling this line low will place the receiver into a low-current state. The module will not be able to receive a signal in this state.
14	RSSI	Received Signal Strength Indicator. This line will supply an analog voltage that is proportional to the strength of the received signal.
15	MODE	Mode Select. GND for parallel channel selection, $V_{CC}$ for serial channel selection
16	$V_{CC}$	Supply Voltage
17	AUDIO	Recovered Analog Output
18	DATA	Digital Data Output. This line will output the demodulated digital data.
19-36	NC	No Connection (SMD only)

## PIN DESCRIPTIONS

Pin #	Name	Equivalent Circuit	Description
1	ANT		50-ohm RF Input
2-8	GND		Analog Ground
9	NC		No Connection
10	CS0		Channel Select 0
11	CS1 / SS CLOCK		Channel Select 1 / Serial Select Clock
12	CS2 / SS DATA		Channel Select 2 / Serial Select Data
13	PDN		Power Down (Active Low)
14	RSSI		Received Signal Strength Indicator
15	MODE		Mode Select
16	$V_{CC}$		Voltage Input 2.8-13V
17	AUDIO		1V <sub>P-P</sub> Analog Output
18	DATA		Digital Data Output
19-36	NC	SMD Only	No Connection

Figure 8: Pin Functions and Equivalent Circuits

## THEORY OF OPERATION

The HP3 is a high-performance multi-channel, dual-conversion superhet receiver capable of recovering both analog (FM) and digital (FSK) information from a matching HP Series transmitter. FM / FSK modulation offers significant advantages over AM or OOK modulation methods, including increased noise immunity and the receiver's ability to capture in the presence of multiple signals. This is especially helpful in crowded bands, like that in which the HP3 operates.

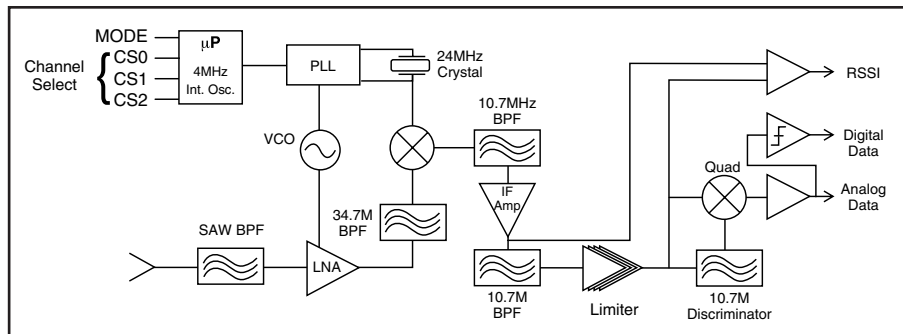

Figure 9: HP3 Series Receiver Block Diagram

The single-ended RF port is matched to 50-ohms to support commonly available antennas, such as those manufactured by Linx. The RF signal coming in from the antenna is filtered by a Surface Acoustic Wave (SAW) filter to attenuate unwanted RF energy. A SAW filter provides significantly higher performance than other filter types, such as an LC bandpass filter.

Once filtered, the signal is amplified by a Low Noise Amplifier (LNA) to increase the receiver sensitivity and lower the overall noise figure of the receiver. After the LNA, the signal is mixed with a synthesized local oscillator operating 34.7MHz below the incoming transmission frequency to produce the first Intermediate Frequency (IF).

The second conversion and FM demodulation is achieved by a high-performance IF strip that mixes the 34.7MHz first conversion frequency with 24.0MHz from a precision crystal oscillator. The resulting second IF of 10.7MHz is then highly amplified in preparation for demodulation.

A quadrature demodulator is used to recover the baseband signal from the carrier. The demodulated waveform is filtered, after which it closely resembles the original signal. The signal is routed to the analog output pin and the data slicer stage, which provides squared digital output via the data output pin. A key feature of the HP3 is the transparency of its digital output, which does not impose balancing or duty-cycle requirements within a range of 100bps to 56kbps.

An on-board microcontroller manages receiver functions and greatly simplifies user interface. The microcontroller reads the channel selection lines and programs the on-board synthesizer. This frees the designer from complex programming requirements and allows for manual or software channel selection. The microcontroller also monitors incoming signal strength and squelches the data output when the signal is not strong enough for accurate data detection.

## POWER-UP SEQUENCE

As previously mentioned, the HP3 is controlled by an on-board microprocessor. When power is applied, the microprocessor executes the receiver start-up sequence, after which the receiver is ready to receive valid data.

The adjacent figure shows the start-up sequence. This sequence is executed when power is applied to the  $V_{CC}$  line or when the PDN line is taken high.

On power-up, the microprocessor reads the external channel selection lines and sets the frequency synthesizer to the appropriate channel. Once the frequency synthesizer has stabilized, the receiver is ready to accept data.

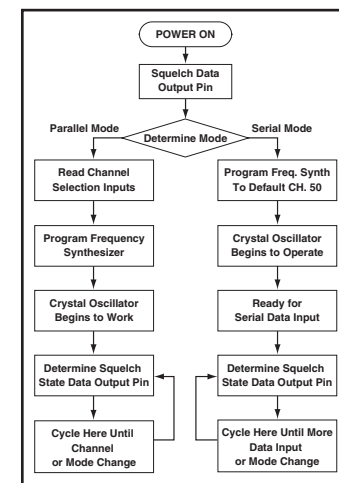

Figure 10: Start-Up Sequence

## POWER SUPPLY

The HP3 incorporates a precision, low-dropout regulator on-board, which allows operation over an input voltage range of 2.8 to 13 volts DC. Despite this regulator, it is still important to provide a supply that is free of noise. Power supply noise can significantly affect the receiver sensitivity; therefore, providing a clean power supply for the module should be a high priority during design.

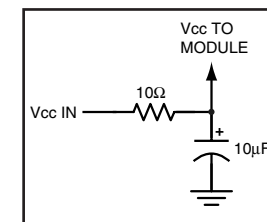

Figure 11: Supply Filter

A 10 $\Omega$  resistor in series with the supply followed by a 10 $\mu\text{F}$  tantalum capacitor from  $V_{CC}$  to ground will help in cases where the quality of supply power is poor. This filter should be placed close to the module's supply lines. These values may need to be adjusted depending on the noise present on the supply line.

## USING THE PDN PIN

The Power Down (PDN) line can be used to power down the receiver without the need for an external switch. This line has an internal pull-up, so when it is held high or simply left floating, the module will be active.

When the PDN line is pulled to ground, the receiver will enter into a low-current (<10 $\mu\text{A}$ ) power-down mode. During this time the receiver is off and cannot perform any function. It may be useful to note that the startup time coming out of power-down will be slightly less than when applying  $V_{CC}$ .

The PDN line allows easy control of the receiver state from external components, like a microcontroller. By periodically activating the receiver, checking for data, then powering down, the receiver's average current consumption can be greatly reduced, saving power in battery-operated applications.

## THE DATA OUTPUT

The DATA line outputs recovered digital data. It is an open collector output with an internal 4.7k $\Omega$  pull-up. When an RF transmission is not present, or when the received signal strength is too low to ensure proper demodulation, the data output is squelched continuous high. This feature supports direct operation with UARTs, which require their input to be continuously high. An HP3 transmitter and receiver can be directly connected between two UARTs without the need for buffering or logical inversion. It should be noted that the squelch level is set just over the receiver's internal noise threshold. Any external RF activity above that threshold will "break squelch" and produce hashing on the line. While the DATA line will be reliably squelched in low-noise environments, the designer should always plan for the potential of hashing.

## AUDIO OUTPUT

The HP3 Series is optimized for the transmission of serial data; however, it can also be used very effectively to send a variety of analog signals, including audio. The ability of the HP3 to send combinations of audio and data opens new areas of opportunity for creative design.

The analog output of the AUDIO line is valid from 50 Hz to 28 kHz, providing an AC signal of about 1V peak-to-peak. This is a high impedance output and not suitable for directly driving low-impedance loads, such as a speaker. In applications where a low impedance load is to be driven, a buffer circuit should always be used. For example, in the case of a speaker, a simple op-amp circuit such as the one shown below can be used to act as an impedance converter.

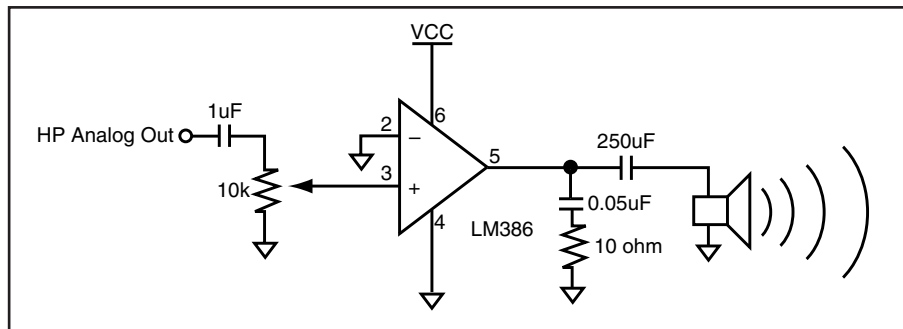

Figure 12: Audio Buffer Amplifier

The transmitter's modulation voltage is critical, since it determines the carrier deviation and distortion. The transmitter input level should be adjusted to achieve the optimum results for your application in your circuit. Please refer to the transmitter data guide for full details.

When used for audio, the analog output of the receiver should be filtered and buffered to obtain maximum sound quality. For voice, a 3-4kHz low-pass filter is often employed. For broader-range sources, such as music, a 12-17kHz cutoff may be more appropriate. In applications that require high-quality audio, a compandor may be used to further improve SNR. The HP3 is capable of providing audio quality comparable to a radio or intercom. For applications where true high fidelity audio is required, the HP3 will probably not be the best choice, and a device optimized for audio should be utilized.

## TIMING CONSIDERATIONS

There are four major timing considerations to be aware of when designing with the HP3 Series receiver. These are shown in the table below.

Parameter	Description	Max.
T1	Time between DATA output transitions	20.0mS
T2	Channel change time (time to valid data)	1.5mS
T3	Receiver turn-on time via PDN	3.0mS
T4	Receiver turn-on time via V <sub>CC</sub>	7.0mS

T1 is the maximum amount of time that can elapse without a data transition. Data must always be considered in both the analog and the digital domain. Because the data stream is asynchronous and no particular format is imposed, it is possible for the data to meet the receiver's data rate requirement yet violate the analog frequency requirements. For example, if a 255 (OFF hex) were sent continuously, the receiver would view the data as a DC level. It would hold that level until a transition was required to meet the minimum frequency specification. If no transition occurred, data integrity could not be guaranteed. While no particular structure or balancing requirement is imposed, the designer must ensure that both analog and digital signals meet the transition specification.

T2 is the worst-case time needed for a powered-up module to switch between channels after a valid channel selection. This time does not include external overhead for loading a desired channel in the serial channel-selection mode.

T3 is the time to receiver readiness from the PDN line going high. Receiver readiness is determined by valid data on the DATA line. This assumes an incoming data stream and the presence of stable supply on V<sub>CC</sub>.

T4 is the time to receiver readiness from the application of V<sub>CC</sub>. Receiver readiness is determined by valid data on the DATA line. This assumes an incoming data stream and the PDN line is high or open.

## RECEIVING DATA

Once an RF link has been established, the challenge becomes how to effectively transfer data across it. While a properly designed RF link provides reliable data transfer under most conditions, there are still distinct differences from a wired link that must be addressed. Since the modules do not incorporate internal encoding or decoding, the user has tremendous flexibility in how data is handled.

It is important to separate the types of transmissions that are technically possible from those that are legally allowed in the country of operation. Application Notes AN-00126, AN-00140 and Part 15, Section 249 of the FCC rules should be reviewed for details on acceptable transmission content in the U.S.

If you want to transfer simple control or status signals (such as button presses) and your product does not have a microprocessor or you wish to avoid protocol development, consider using an encoder / decoder IC set. These chips are available from several manufacturers, including Linx. They take care of all encoding and decoding functions and provide a number of data lines to which switches can be directly connected. Address bits are usually provided for security and to allow the addressing of multiple receivers independently. These ICs are an excellent way to bring basic remote control products to market quickly and inexpensively. It is also a simple task to interface with inexpensive microprocessors or one of many IR, remote control, DTMF, or modem ICs.

# CHANNEL SELECTION

## Parallel Selection

All HP3 receiver models feature eight parallel selectable channels. Parallel Mode is selected by grounding the MODE line. In this mode, channel selection is determined by the logic states of pins CS0, CS1, and CS2, as shown in the adjacent table. A '0' represents ground and a '1' the positive supply. The on-board microprocessor performs all PLL loading functions, eliminating external programming and allowing channel selection via DIP switches or a product's processor.

CS2	CS1	CS0	Channel	Frequency
0	0	0	0	903.37
0	0	1	1	906.37
0	1	0	2	907.87
0	1	1	3	909.37
1	0	0	4	912.37
1	0	1	5	915.37
1	1	0	6	919.87
1	1	1	7	921.37

Table 2: Parallel Channel Selection Table

## Serial Selection

In addition to the Parallel Mode, PS versions of the HP3 also feature 100 serially selectable channels. The Serial Mode is entered when the MODE line is left open or held high. In this condition, CS1 and CS2 become a synchronous serial port, with CS1 serving as the clock line and CS2 as the data line. The module is easily programmed by sending and latching the binary number (0 to 100) of the desired channel (see the adjacent Serial Channel Selection Table). With no additional effort, the module's microprocessor handles the complex PLL loading functions.

The Serial Mode is straightforward; however, minimum timings and bit order must be followed. Loading is initiated by taking the clock line high and the data line low as shown. The eight-bit channel number is then clocked-in one bit at a time, with the LSB first.

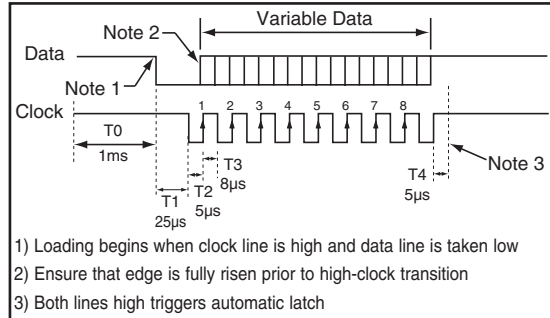

(T0) Time between packets or prior to data startup .....	1mS min.
(T1) Data-LO / Clock-HI to Data-LO / Clock-LO .....	25µS min.
(T2) Clock-LO to Clock-HI .....	5µS min.
(T3) Clock-HI to Clock-LO .....	8µS min.
(T4) Data-HI / Clock-HI .....	5µS min.
<b>Total Packet Time .....</b>	<b>157µS min.</b>

Figure 13: PLL Serial Data Timing

There is no maximum time for this process, only the minimum times that must be observed. After the eighth bit, both the clock and data lines should be taken high to trigger the automatic data latch. A typical software routine can complete the loading sequence in under 200uS. Sample code is available on the Linx website.

NOTE: When the module is powered up in the Serial Mode, it will default to channel 50 until changed by user software. This allows testing apart from external programming and prevents out-of-band operation. When programmed properly, the dwell time on this default channel can be less than 200uS. Channel 50 is not counted as a usable channel since data errors may occur as transmitters also default to channel 50 on startup. If a loading error occurs, such as a channel number >100 or a timing problem, the receiver will default to serial channel 0. This is useful for debugging as it verifies serial port activity.

# SERIAL CHANNEL SELECTION TABLE

CHANNEL	TX FREQUENCY	RX LO	CHANNEL	TX FREQUENCY	RX LO
0	902.62	867.92	51	915.37	880.67
1	902.87	868.17	52	915.62	880.92
2	903.12	868.42	53	915.87	881.17
3	903.37	868.67	54	916.12	881.42
4	903.62	868.92	55	916.37	881.67
5	903.87	869.17	56	916.62	881.92
6	904.12	869.42	57	916.87	882.17
7	904.37	869.67	58	917.12	882.42
8	904.62	869.92	59	917.37	882.67
9	904.87	870.17	60	917.62	882.92
10	905.12	870.42	61	917.87	883.17
11	905.37	870.67	62	918.12	883.42
12	905.62	870.92	63	918.37	883.67
13	905.87	871.17	64	918.62	883.92
14	906.12	871.42	65	918.87	884.17
15	906.37	871.67	66	919.12	884.42
16	906.62	871.92	67	919.37	884.67
17	906.87	872.17	68	919.62	884.92
18	907.12	872.42	69	919.87	885.17
19	907.37	872.67	70	920.12	885.42
20	907.62	872.92	71	920.37	885.67
21	907.87	873.17	72	920.62	885.92
22	908.12	873.42	73	920.87	886.17
23	908.37	873.67	74	921.12	886.42
24	908.62	873.92	75	921.37	886.67
25	908.87	874.17	76	921.62	886.92
26	909.12	874.42	77	921.87	887.17
27	909.37	874.67	78	922.12	887.42
28	909.62	874.92	79	922.37	887.67
29	909.87	875.17	80	922.62	887.92
30	910.12	875.42	81	922.87	888.17
31	910.37	875.67	82	923.12	888.42
32	910.62	875.92	83	923.37	888.67
33	910.87	876.17	84	923.62	888.92
34	911.12	876.42	85	923.87	889.17
35	911.37	876.67	86	924.12	889.42
36	911.62	876.92	87	924.37	889.67
37	911.87	877.17	88	924.62	889.92
38	912.12	877.42	89	924.87	890.17
39	912.37	877.67	90	925.12	890.42
40	912.62	877.92	91	925.37	890.67
41	912.87	878.17	92	925.62	890.92
42	913.12	878.42	93	925.87	891.17
43	913.37	878.67	94	926.12	891.42
44	913.62	878.92	95	926.37	891.67
45	913.87	879.17	96	926.62	891.92
46	914.12	879.42	97	926.87	892.17
47	914.37	879.67	98	927.12	892.42
48	914.62	879.92	99	927.37	892.67
49	914.87	880.17	100	927.62	892.92
50*	915.12	880.42			

= Also available in Parallel Mode

\*See NOTE on previous page.

## PROTOCOL GUIDELINES

While many RF solutions impose data formatting and balancing requirements, Linx RF modules do not encode or packetize the signal content in any manner. The received signal will be affected by such factors as noise, edge jitter, and interference, but it is not purposefully manipulated or altered by the modules. This gives the designer tremendous flexibility for protocol design and interface.

Despite this transparency and ease of use, it must be recognized that there are distinct differences between a wired and a wireless environment. Issues such as interference and contention must be understood and allowed for in the design process. To learn more about protocol considerations, we suggest you read Linx Application Note AN-00160.

Errors from interference or changing signal conditions can cause corruption of the data packet, so it is generally wise to structure the data being sent into small packets. This allows errors to be managed without affecting large amounts of data. A simple checksum or CRC could be used for basic error detection. Once an error is detected, the protocol designer may wish to simply discard the corrupt data or implement a more sophisticated scheme to correct it.

## INTERFERENCE CONSIDERATIONS

The RF spectrum is crowded and the potential for conflict with other unwanted sources of RF is very real. While all RF products are at risk from interference, its effects can be minimized by better understanding its characteristics.

Interference may come from internal or external sources. The first step is to eliminate interference from noise sources on the board. This means paying careful attention to layout, grounding, filtering, and bypassing in order to eliminate all radiated and conducted interference paths. For many products, this is straightforward; however, products containing components such as switching power supplies, motors, crystals, and other potential sources of noise must be approached with care. Comparing your own design with a Linx evaluation board can help to determine if and at what level design-specific interference is present.

External interference can manifest itself in a variety of ways. Low-level interference will produce noise and hashing on the output and reduce the link's overall range.

High-level interference is caused by nearby products sharing the same frequency or from near-band high-power devices. It can even come from your own products if more than one transmitter is active in the same area. It is important to remember that only one transmitter at a time can occupy a frequency, regardless of the coding of the transmitted signal. This type of interference is less common than those mentioned previously, but in severe cases it can prevent all useful function of the affected device.

Although technically it is not interference, multipath is also a factor to be understood. Multipath is a term used to refer to the signal cancellation effects that occur when RF waves arrive at the receiver in different phase relationships. This effect is a particularly significant factor in interior environments where objects provide many different signal reflection paths. Multipath cancellation results in lowered signal levels at the receiver and, thus, shorter useful distances for the link.

## TYPICAL APPLICATIONS

The figure below shows a typical RS-232 circuit using the HP3 Series receiver and a Maxim MAX232. The receiver outputs a serial data stream and the MAX232 converts that to RS-232 compliant signals. The MODE line is grounded so the channels are selected by the DIP switches.

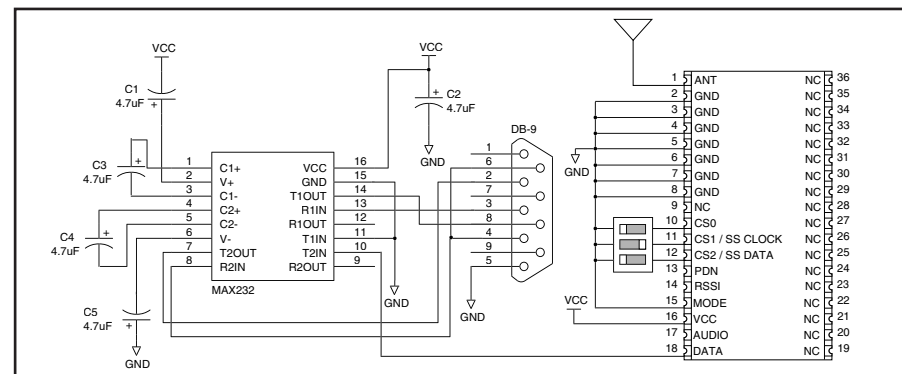

Figure 14: HP3 Receiver and MAX232 IC

The figure below shows a circuit using the QS Series USB module. The QS converts the data from the receiver into USB compliant signals to be sent to a PC. The MODE line is high, so the module is in Serial Channel Select mode. The RTS and DTR lines are used to load the channels. Application Note AN-00155 shows sample source code that can be adapted to use on a PC. The QS Series Data Guide and Application Note AN-00200 discuss the hardware and software set-up required for QS Series modules.

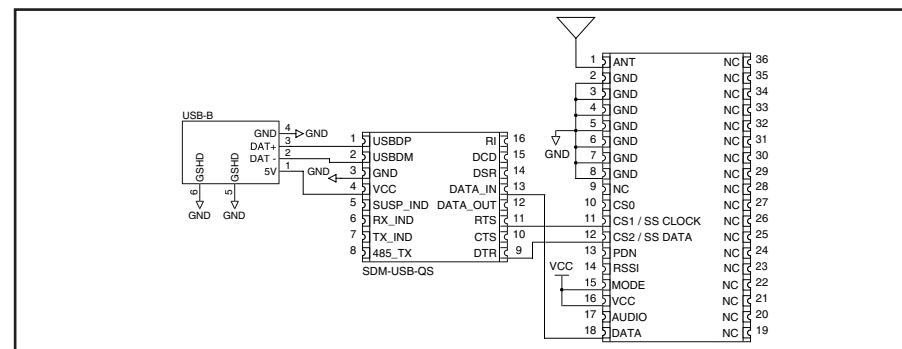

Figure 15: HP3 Receiver and Linx QS Series USB Module

The receiver can also be connected to a microcontroller, which will interpret the data and take specific actions. A UART may be employed or an I/O line may be used to continuously monitor the DATA line for a valid packet. The receiver may be connected directly to the microcontroller without the need for buffering or amplification.

## BOARD LAYOUT GUIDELINES

If you are at all familiar with RF devices, you may be concerned about specialized board layout requirements. Fortunately, because of the care taken by Linx in designing the modules, integrating them is very straightforward. Despite this ease of application, it is still necessary to maintain respect for the RF stage and exercise appropriate care in layout and application in order to maximize performance and ensure reliable operation. The antenna can also be influenced by layout choices. Please review this data guide in its entirety prior to beginning your design. By adhering to good layout principles and observing some basic design rules, you will be on the path to RF success.

The adjacent figure shows the suggested PCB footprint for the module. The actual pad dimensions are shown in the Pad Layout section of this manual. A ground plane (as large as possible) should be placed on a lower layer of your PC board opposite the module. This ground plane can also be critical to the performance of your antenna, which will be discussed later. There should not be any ground or traces under the module on the same layer as the module, just bare PCB.

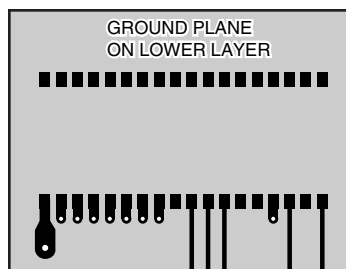

Figure 16: Suggested PCB Layout

During prototyping, the module should be soldered to a properly laid-out circuit board. The use of prototyping or “perf” boards will result in horrible performance and is strongly discouraged.

No conductive items should be placed within 0.15in of the module’s top or sides.

Do not route PCB traces directly under the module. The underside of the module has numerous signal-bearing traces and vias that could short or couple to traces on the product’s circuit board.

The module’s ground lines should each have their own via to the ground plane and be as short as possible.

AM / OOK receivers are particularly subject to noise. The module should, as much as reasonably possible, be isolated from other components on your PCB, especially high-frequency circuitry such as crystal oscillators, switching power supplies, and high-speed bus lines. Make sure internal wiring is routed away from the module and antenna, and is secured to prevent displacement.

The power supply filter should be placed close to the module’s  $V_{CC}$  line.

In some instances, a designer may wish to encapsulate or “pot” the product. Many Linx customers have done this successfully; however, there are a wide variety of potting compounds with varying dielectric properties. Since such compounds can considerably impact RF performance, it is the responsibility of the designer to carefully evaluate and qualify the impact and suitability of such materials.

The trace from the module to the antenna should be kept as short as possible. A simple trace is suitable for runs up to 1/8-inch for antennas with wide bandwidth characteristics. For longer runs or to avoid detuning narrow bandwidth antennas, such as a helical, use a 50-ohm coax or 50-ohm microstrip transmission line as described in the following section.

## MICROSTRIP DETAILS

A transmission line is a medium whereby RF energy is transferred from one place to another with minimal loss. This is a critical factor, especially in high-frequency products like Linx RF modules, because the trace leading to the module’s antenna can effectively contribute to the length of the antenna, changing its resonant bandwidth. In order to minimize loss and detuning, some form of transmission line between the antenna and the module should be used, unless the antenna can be placed very close (<1/8in.) to the module. One common form of transmission line is a coax cable, another is the microstrip. This term refers to a PCB trace running over a ground plane that is designed to serve as a transmission line between the module and the antenna. The width is based on the desired characteristic impedance of the line, the thickness of the PCB, and the dielectric constant of the board material. For standard 0.062in thick FR-4 board material, the trace width would be 111 mils. The correct trace width can be calculated for other widths and materials using the information below. Handy software for calculating microstrip lines is also available on the Linx website, [www.linxtechnologies.com](http://www.linxtechnologies.com).

$$E_e = \frac{E_r + 1}{2} + \frac{E_r - 1}{2} \cdot \frac{1}{\sqrt{1 + 12d/W}}$$

$$Z_0 = \begin{cases} \frac{60}{\sqrt{E_e}} \cdot \ln\left(\frac{8d}{W} + \frac{W}{4d}\right) & \text{For } \frac{W}{d} \leq 1 \\ \frac{120\pi}{\sqrt{E_e} \cdot \left(\frac{W}{d} + 1.393 + 0.667 \cdot \ln\left(\frac{W}{d} + 1.444\right)\right)} & \text{For } \frac{W}{d} \geq 1 \end{cases}$$

$E_r$  = Dielectric constant of PCB material

Figure 17: Microstrip Formulas

Dielectric Constant	Width/Height (W/d)	Effective Dielectric Constant	Characteristic Impedance
4.80	1.8	3.59	50.0
4.00	2.0	3.07	51.0
2.55	3.0	2.12	48.0



## PAD LAYOUT

The following pad layout diagram is designed to facilitate both hand and automated assembly.

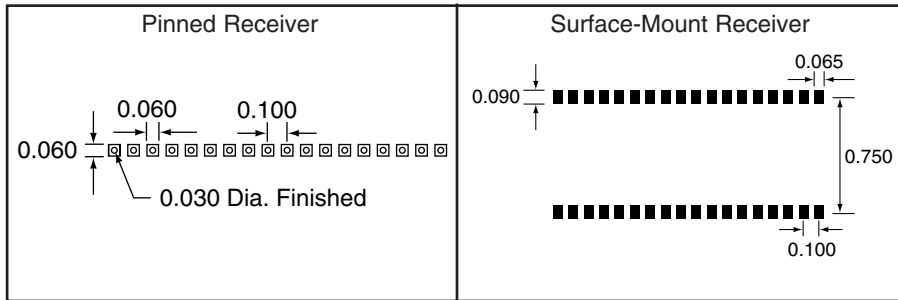

Figure 18: Recommended PCB Layout

## PRODUCTION GUIDELINES

The modules are housed in a hybrid SMD package that supports hand or automated assembly techniques. Since the modules contain discrete components internally, the assembly procedures are critical to ensuring the reliable function of the modules. The following procedures should be reviewed with and practiced by all assembly personnel.

## HAND ASSEMBLY

Pads located on the bottom of the module are the primary mounting surface. Since these pads are inaccessible during mounting, castellations that run up the side of the module have been provided to facilitate solder wicking to the module's underside. This allows for very quick hand soldering for prototyping and small volume production.

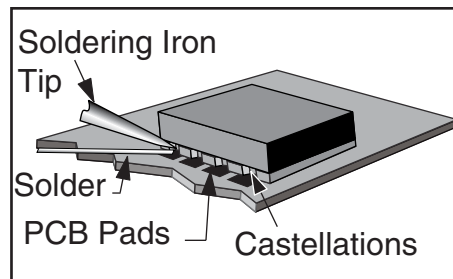

Figure 19: Soldering Technique

If the recommended pad guidelines have been followed, the pads will protrude slightly past the edge of the module. Use a fine soldering tip to heat the board pad and the castellation, then introduce solder to the pad at the module's edge. The solder will wick underneath the module, providing reliable attachment. Tack one module corner first and then work around the device, taking care not to exceed the times listed below.

### Absolute Maximum Solder Times

**Hand-Solder Temp. TX +225°C for 10 Seconds**

**Hand-Solder Temp. RX +225°C for 10 Seconds**

**Recommended Solder Melting Point +180°C**

**Reflow Oven: +220°C Max. (See adjoining diagram)**

## AUTOMATED ASSEMBLY

For high-volume assembly, most users will want to auto-place the modules. The modules have been designed to maintain compatibility with reflow processing techniques; however, due to their hybrid nature, certain aspects of the assembly process are far more critical than for other component types.

Following are brief discussions of the three primary areas where caution must be observed.

### Reflow Temperature Profile

The single most critical stage in the automated assembly process is the reflow stage. The reflow profile below should not be exceeded, since excessive temperatures or transport times during reflow will irreparably damage the modules. Assembly personnel will need to pay careful attention to the oven's profile to ensure that it meets the requirements necessary to successfully reflow all components while still remaining within the limits mandated by the modules. The figure below shows the recommended reflow oven profile for the modules.

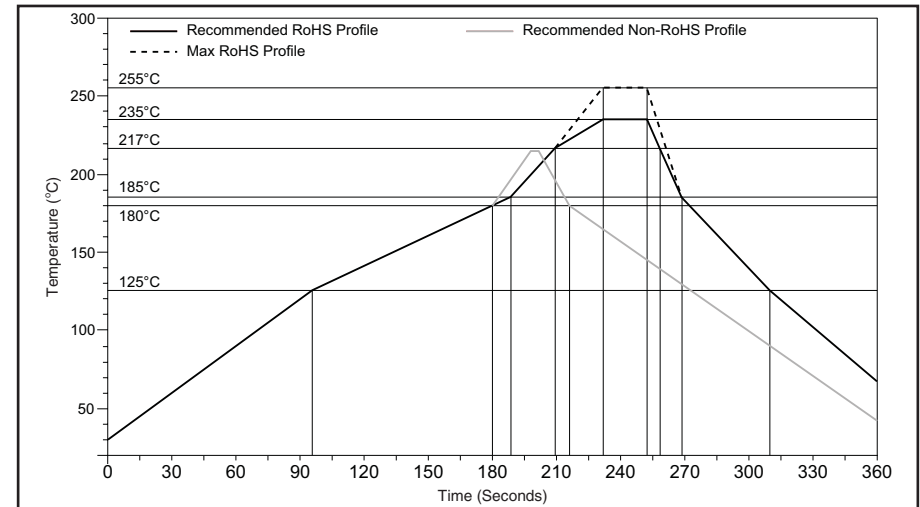

Figure 20: Maximum Reflow Profile

### Shock During Reflow Transport

Since some internal module components may reflow along with the components placed on the board being assembled, it is imperative that the modules not be subjected to shock or vibration during the time solder is liquid. Should a shock be applied, some internal components could be lifted from their pads, causing the module to not function properly.

### Washability

The modules are wash resistant, but are not hermetically sealed. Linx recommends wash-free manufacturing; however, the modules can be subjected to a wash cycle provided that a drying time is allowed prior to applying electrical power to the modules. The drying time should be sufficient to allow any moisture that may have migrated into the module to evaporate, thus eliminating the potential for shorting damage during power-up or testing. If the wash contains contaminants, the performance may be adversely affected, even after drying.

## ANTENNA CONSIDERATIONS

The choice of antennas is a critical and often overlooked design consideration. The range, performance, and legality of an RF link are critically dependent upon the antenna. While adequate antenna performance can often be obtained by trial and error methods, antenna design and matching is a complex task. A professionally designed antenna, such as those from Linx, will help ensure maximum performance and FCC compliance.

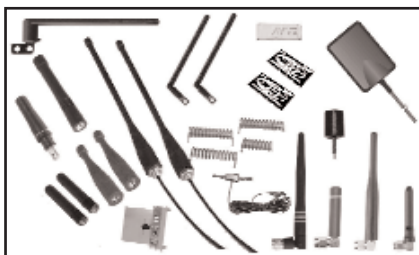

Figure 21: Linx Antennas

Linx transmitter modules typically have an output power that is slightly higher than the legal limits. This allows the designer to use an inefficient antenna, such as a loop trace or helical, to meet size, cost, or cosmetic requirements and still achieve full legal output power for maximum range. If an efficient antenna is used, then some attenuation of the output power will likely be needed. This can easily be accomplished by using the LADJ line or a T-pad attenuator. For more details on T-pad attenuator design, please see Application Note AN-00150.

A receiver antenna should be optimized for the frequency or band in which the receiver operates and to minimize the reception of off-frequency signals. The efficiency of the receiver's antenna is critical to maximizing range performance. Unlike the transmitter antenna, where legal operation may mandate attenuation or a reduction in antenna efficiency, the receiver's antenna should be optimized as much as is practical.

It is usually best to utilize a basic quarter-wave whip until your prototype product is operating satisfactorily. Other antennas can then be evaluated based on the cost, size, and cosmetic requirements of the product. You may wish to review Application Note AN-00500 "Antennas: Design, Application, Performance"

## ANTENNA SHARING

In cases where a transmitter and receiver module are combined to form a transceiver, it is often advantageous to share a single antenna. To accomplish this, an antenna switch must be used to provide isolation between the modules so that the full transmitter output power is not put on the sensitive front end of the receiver. There are a wide variety of antenna switches that are cost-effective and easy to use. Among the most popular are switches from Macom and NEC. Look for an antenna switch that has high isolation and low loss at the desired frequency of operation. Generally, the Tx or Rx status of a switch will be controlled by a product's microprocessor, but the user may also make the selection manually. In some cases, where the characteristics of the Tx and Rx antennas need to be different or antenna switch losses are unacceptable, it may be more appropriate to utilize two discrete antennas.

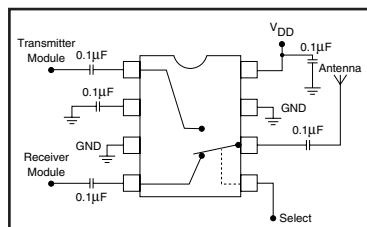

Figure 22: Typical Antenna Switch

## GENERAL ANTENNA RULES

The following general rules should help in maximizing antenna performance.

1. Proximity to objects such as a user's hand, body, or metal objects will cause an antenna to detune. For this reason, the antenna shaft and tip should be positioned as far away from such objects as possible.

2. Optimum performance will be obtained from a 1/4- or 1/2-wave straight whip mounted at a right angle to the ground plane. In many cases, this isn't desirable for practical or ergonomic reasons, thus, an alternative antenna style such as a helical, loop, or patch may be utilized

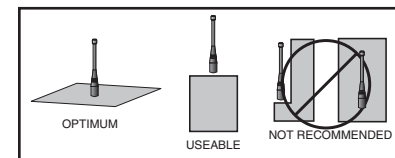

Figure 23: Ground Plane Orientation and the corresponding sacrifice in performance accepted.

3. If an internal antenna is to be used, keep it away from other metal components, particularly large items like transformers, batteries, PCB tracks, and ground planes. In many cases, the space around the antenna is as important as the antenna itself. Objects in close proximity to the antenna can cause direct detuning, while those farther away will alter the antenna's symmetry.

4. In many antenna designs, particularly 1/4-wave whips, the ground plane acts as a counterpoise, forming, in essence, a 1/2-wave dipole. For this reason, adequate ground plane area is essential. The ground plane can be a metal case or ground-fill areas on a circuit board. Ideally, it should have a surface area  $\geq$  the overall length of the 1/4-wave radiating element. This is often not practical due to size and configuration constraints. In these instances, a designer must make the best use of the area available to create as much ground plane as possible in proximity to the base of the antenna. In cases where the antenna is remotely located or the antenna is not in close proximity to a circuit board, ground plane, or grounded metal case, a metal plate may be used to maximize the antenna's performance.

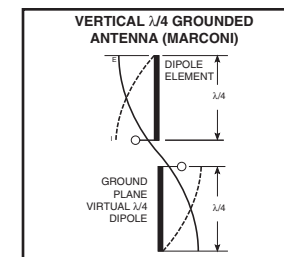

Figure 24: Dipole Antenna

5. Remove the antenna as far as possible from potential interference sources. Any frequency of sufficient amplitude to enter the receiver's front end will reduce system range and can even prevent reception entirely. Switching power supplies, oscillators, or even relays can also be significant sources of potential interference. The single best weapon against such problems is attention to placement and layout. Filter the module's power supply with a high-frequency bypass capacitor. Place adequate ground plane under potential sources of noise to shunt noise to ground and prevent it from coupling to the RF stage. Shield noisy board areas whenever practical.

6. In some applications, it is advantageous to place the module and antenna away from the main equipment. This can avoid interference problems and allows the antenna to be oriented for optimum performance. Always use 50Ω coax, like RG-174, for the remote feed.

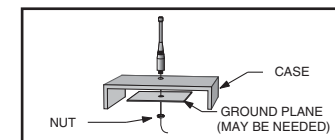

Figure 25: Remote Ground Plane

## COMMON ANTENNA STYLES

There are literally hundreds of antenna styles and variations that can be employed with Linx RF modules. Following is a brief discussion of the styles most commonly utilized. Additional antenna information can be found in Linx Application Notes AN-00100, AN-00140, and AN-00500. Linx antennas and connectors offer outstanding performance at a low price.

### Whip Style



$$L = \frac{234}{F \text{ MHz}}$$

Where:  
L = length in feet of quarter-wave length  
F = operating frequency in megahertz

A whip-style antenna provides outstanding overall performance and stability. A low-cost whip can be easily fabricated from a wire or rod, but most designers opt for the consistent performance and cosmetic appeal of a professionally-made model. To meet this need, Linx offers a wide variety of straight and reduced-height whip-style antennas in permanent and connectorized mounting styles.

The wavelength of the operational frequency determines an antenna's overall length. Since a full wavelength is often quite long, a partial 1/2- or 1/4-wave antenna is normally employed. Its size and natural radiation resistance make it well matched to Linx modules. The proper length for a straight 1/4-wave can be easily determined using the adjacent formula. It is also possible to reduce the overall height of the antenna by using a helical winding. This reduces the antenna's bandwidth, but is a great way to minimize the antenna's physical size for compact applications. This also means that the physical appearance is not always an indicator of the antenna's frequency.

### Specialty Styles



Linx offers a wide variety of specialized antenna styles. Many of these styles utilize helical elements to reduce the overall antenna size while maintaining reasonable performance. A helical antenna's bandwidth is often quite narrow and the antenna can detune in proximity to other objects, so care must be exercised in layout and placement.

### Loop Style



A loop- or trace-style antenna is normally printed directly on a product's PCB. This makes it the most cost-effective of antenna styles. The element can be made self-resonant or externally resonated with discrete components, but its actual layout is usually product specific. Despite the cost advantages, loop-style antennas are generally inefficient and useful only for short-range applications. They are also very sensitive to changes in layout and PCB dielectric, which can cause consistency issues during production. In addition, printed styles are difficult to engineer, requiring the use of expensive equipment, including a network analyzer. An improperly designed loop will have a high SWR at the desired frequency, which can cause instability in the RF stage.

Linx offers low-cost planar and chip antennas that mount directly to a product's PCB. These tiny antennas do not require testing and provide excellent performance in light of their small size. They offer a preferable alternative to the often-problematic "printed" antenna.



## ONLINE RESOURCES



[www.linxtechnologies.com](http://www.linxtechnologies.com)

- Latest News
- Data Guides
- Application Notes
- Knowledgebase
- Software Updates



If you have questions regarding any Linx product and have Internet access, make [www.linxtechnologies.com](http://www.linxtechnologies.com) your first stop. Our website is organized in an intuitive format to immediately give you the answers you need. Day or night, the Linx website gives you instant access to the latest information regarding the products and services of Linx. It's all here: manual and software updates, application notes, a comprehensive knowledgebase, FCC information, and much more. Be sure to visit often!



[www.antennafactor.com](http://www.antennafactor.com)

The Antenna Factor division of Linx offers a diverse array of antenna styles, many of which are optimized for use with our RF modules. From innovative embeddable antennas to low-cost whips, dipoles to Yagis, and even GPS, Antenna Factor likely has an antenna for you, or can design one to meet your requirements.



[www.connectorcity.com](http://www.connectorcity.com)

Through its Connector City division, Linx offers a wide selection of high-quality RF connectors, including FCC-compliant types such as RP-SMAs that are an ideal match for our modules and antennas. Connector City focuses on high-volume OEM requirements, which allows standard and custom RF connectors to be offered at a remarkably low cost.



## LEGAL CONSIDERATIONS

**NOTE:** Linx RF modules are designed as component devices that require external components to function. The modules are intended to allow for full Part 15 compliance; however, they are not approved by the FCC or any other agency worldwide. The purchaser understands that approvals may be required prior to the sale or operation of the device, and agrees to utilize the component in keeping with all laws governing its use in the country of operation.

When working with RF, a clear distinction must be made between what is technically possible and what is legally acceptable in the country where operation is intended. Many manufacturers have avoided incorporating RF into their products as a result of uncertainty and even fear of the approval and certification process. Here at Linx, our desire is not only to expedite the design process, but also to assist you in achieving a clear idea of what is involved in obtaining the necessary approvals to legally market your completed product.

In the United States, the approval process is actually quite straightforward. The regulations governing RF devices and the enforcement of them are the responsibility of the Federal Communications Commission (FCC). The regulations are contained in Title 47 of the Code of Federal Regulations (CFR). Title 47 is made up of numerous volumes; however, all regulations applicable to this module are contained in Volume 0-19. It is strongly recommended that a copy be obtained from the Government Printing Office in Washington or from your local government bookstore. Excerpts of applicable sections are included with Linx evaluation kits or may be obtained from the Linx Technologies website, [www.linxtechnologies.com](http://www.linxtechnologies.com). In brief, these rules require that any device that intentionally radiates RF energy be approved, that is, tested for compliance and issued a unique identification number. This is a relatively painless process. Linx offers full FCC pre-screening, and final compliance testing is then performed by one of the many independent testing laboratories across the country. Many labs can also provide other certifications that the product may require at the same time, such as UL, Class A / B, etc. Once your completed product has passed, you will be issued an ID number that is to be clearly placed on each product manufactured.

Questions regarding interpretations of the Part 2 and Part 15 rules or measurement procedures used to test intentional radiators, such as Linx RF modules, for compliance with the technical standards of Part 15, should be addressed to:

Federal Communications Commission  
Office of Engineering and Technology Laboratory Division  
7435 Oakland Mills Road  
Columbia, MD 21046-1609

Phone: (301) 362-3000 Fax: (301) 362-3290 E-Mail: [labinfo@fcc.gov](mailto:labinfo@fcc.gov)

International approvals are slightly more complex, although Linx modules are designed to allow all international standards to be met. If you are considering the export of your product abroad, you should contact Linx Technologies to determine the specific suitability of the module to your application.

All Linx modules are designed with the approval process in mind and thus much of the frustration that is typically experienced with a discrete design is eliminated. Approval is still dependent on many factors, such as the choice of antennas, correct use of the frequency selected, and physical packaging. While some extra cost and design effort are required to address these issues, the additional usefulness and profitability added to a product by RF makes the effort more than worthwhile.

## ACHIEVING A SUCCESSFUL RF IMPLEMENTATION

Adding an RF stage brings an exciting new dimension to any product. It also means that additional effort and commitment will be needed to bring the product successfully to market. By utilizing premade RF modules, such as the LR Series, the design and approval process is greatly simplified. It is still important, however, to have an objective view of the steps necessary to ensure a successful RF integration. Since the capabilities of each customer vary widely, it is difficult to recommend one particular design path, but most projects follow steps similar to those shown at the right.

In reviewing this sample design path, you may notice that Linx offers a variety of services (such as antenna design and FCC prequalification) that are unusual for a high-volume component manufacturer. These services, along with an exceptional level of technical support, are offered because we recognize that RF is a complex science requiring the highest caliber of products and support. "Wireless Made Simple" is more than just a motto, it's our commitment. By choosing Linx as your RF partner and taking advantage of the resources we offer, you will not only survive implementing RF, you may even find the process enjoyable.

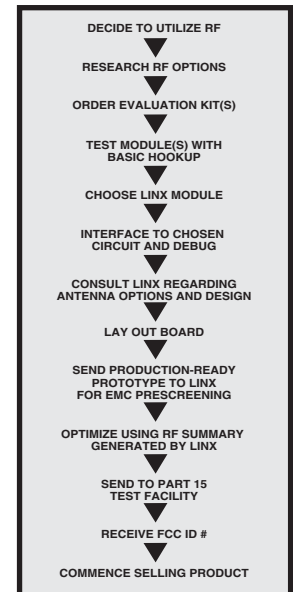

**Typical Steps For Implementing RF**

## HELPFUL APPLICATION NOTES FROM LINX

It is not the intention of this manual to address in depth many of the issues that should be considered to ensure that the modules function correctly and deliver the maximum possible performance. As you proceed with your design, you may wish to obtain one or more of the following application notes, which address in depth key areas of RF design and application of Linx products. These applications notes are available online at [www.linxtechnologies.com](http://www.linxtechnologies.com) or by contacting the Linx literature department.

NOTE	APPLICATION NOTE TITLE
AN-00100	RF 101: Information for the RF Challenged
AN-00126	Considerations For Operation Within The 902-928MHz Band
AN-00130	Modulation Techniques For Low-Cost RF Data Links
AN-00140	The FCC Road: Part 15 From Concept To Approval
AN-00155	Serial Loading Techniques for the HP Series 3
AN-00160	Considerations For Sending Data Over a Wireless Link
AN-00500	Antennas: Design, Application, Performance



## U.S. CORPORATE HEADQUARTERS

### **LINX TECHNOLOGIES, INC.**

**159 ORT LANE  
MERLIN, OR 97532**

**PHONE: (541) 471-6256**

**FAX: (541) 471-6251**

**[www.linxtechnologies.com](http://www.linxtechnologies.com)**

### **Disclaimer**

Linx Technologies is continually striving to improve the quality and function of its products. For this reason, we reserve the right to make changes to our products without notice. The information contained in this Overview Guide is believed to be accurate as of the time of publication. Specifications are based on representative lot samples. Values may vary from lot-to-lot and are not guaranteed. "Typical" parameters can and do vary over lots and application. Linx Technologies makes no guarantee, warranty, or representation regarding the suitability of any product for use in any specific application. It is the customer's responsibility to verify the suitability of the part for the intended application. NO LINX PRODUCT IS INTENDED FOR USE IN ANY APPLICATION WHERE THE SAFETY OF LIFE OR PROPERTY IS AT RISK.

Linx Technologies DISCLAIMS ALL WARRANTIES OF MERCHANTABILITY AND FITNESS FOR A PARTICULAR PURPOSE. IN NO EVENT SHALL LINX TECHNOLOGIES BE LIABLE FOR ANY OF CUSTOMER'S INCIDENTAL OR CONSEQUENTIAL DAMAGES ARISING IN ANY WAY FROM ANY DEFECTIVE OR NON-CONFORMING PRODUCTS OR FOR ANY OTHER BREACH OF CONTRACT BY LINX TECHNOLOGIES. The limitations on Linx Technologies' liability are applicable to any and all claims or theories of recovery asserted by Customer, including, without limitation, breach of contract, breach of warranty, strict liability, or negligence. Customer assumes all liability (including, without limitation, liability for injury to person or property, economic loss, or business interruption) for all claims, including claims from third parties, arising from the use of the Products. The Customer will indemnify, defend, protect, and hold harmless Linx Technologies and its officers, employees, subsidiaries, affiliates, distributors, and representatives from and against all claims, damages, actions, suits, proceedings, demands, assessments, adjustments, costs, and expenses incurred by Linx Technologies as a result of or arising from any Products sold by Linx Technologies to Customer. Under no conditions will Linx Technologies be responsible for losses arising from the use or failure of the device in any application, other than the repair, replacement, or refund limited to the original product purchase price. Devices described in this publication may contain proprietary, patented, or copyrighted techniques, components, or materials. Under no circumstances shall any user be conveyed any license or right to the use or ownership of such items.